



SMARTER LIGHTING CHOICES

SINCE 1998



INTERIOR LIGHTING



EXTERIOR LIGHTING



SMART LIGHTING
CONTROLS



LED INTERIOR EMERGENCY

A versatile range of
LED interior emergency
luminaires compliant
to AS/NZS 2293



24m



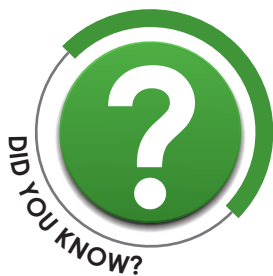

Before selecting an Emergency Lighting product look out for the marks of Compliance and Safety. Starting with the RCM mark, this signals that the product has been tested to all relevant Australian Safety standards and EMC, to ensure the product delivers its designed safety performance.

In addition look out for the inclusion of long life Lithium Battery technology to ensure the system maintenance is kept to a minimum and the product performs to a minimum duration of 90 minutes when an emergency event occurs.



Now remember, compliance to AS/NZS2293 calls for mandatory scheduled testing of all emergency lighting systems.



For Interior products, the designated IP rating is "from below the ceiling" unless otherwise specified.





S-FIRE SELK1500ISF - 1.6W

SELK1500ISF S-FIRE LED emergency luminaire, complete with adaptor ring

Application

A perfect choice for apartments or commercial space

Design Specifications

- Compliant to AS/NZS 2293, emergency spacing classification D32, non-maintained
- Polycarbonate body profile, IP20, double insulation, Ø92 mm cut-out, adapter plate cutout Ø110 mm - Ø150 mm, outside plate Ø170 mm
- LED charge status display and test switch
- 1.2 m flex & 3 pin plug fitted for easy plug and play installation, IC-4 rated
- Integral converter and replaceable battery pack LiFePO4 3.2V 1.5Ah (SELK1500ISF BATTERY)
- Guaranteed 90 minutes emergency function
- Intelligent automatic recharging function, 16 hour recharge time and deep discharge protection



Dimensions

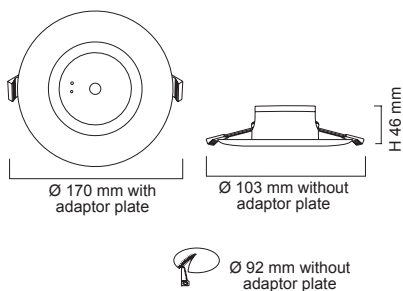

Technical Specifications

Model No.	Input (V)/(Hz)	Emergency Power (W)	Battery Type	CCT (K)	Emergency classification	Fitting Colour
SELK1500ISF	240/50	1.6	IFR18650 3.2V, 1.5Ah	4000	D32	White

For terms and conditions of catalogue data use, refer to INDEX



S-FIRE SELK1500SF2 - 4W

SELK1500SF2 S-FIRE LED 4 watt emergency luminaire with adaptor ring

Application

A perfect choice for apartments or commercial space requiring compliance to AS/NZS 2293

Design Specifications

- Compliant to AS/NZS2293, with an impressive D63 emergency spacing classification, non-maintained
- Polycarbonate body profile, double insulation, Ø72mm cut-out and includes a Ø145mm adaptor ring (Max. Ø130mm cut-out)
- 4 watt system, LED charge status display and test switch, with remote control gear and high performance integral Lithium LiFePO4 battery
- 1.2 m flex & 3 pin plug fitted, IC-4 rated (luminaire head only), trim colour white
- Guaranteed 90 minutes emergency function
- Intelligent automatic recharging function, 16 hour recharge time and deep discharge protection
- Optional surface mount kit SELK1500SF2SM/P available



Dimensions

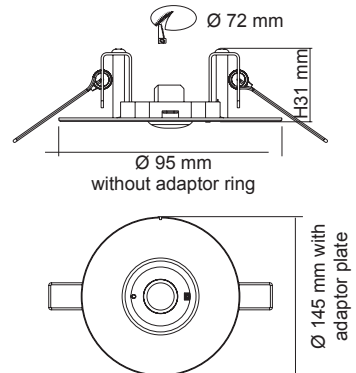

Technical Specifications

Model No.	Input (V)/(Hz)	Emergency Power (W)	Battery Type	CCT (K)	CRI	Emergency classification	Fitting Colour
SELK1500SF2	240/50	4	IFR18650 3.2V, 1.5Ah	6000	> 80	D63	White



EMERGENCY EXIT SELK1500EX2 - 5.6W

SELK1500EX2 Emergency Exit 24 metre viewing

Application

A perfect choice for apartments or commercial spaces

Design Specifications

- Compliant to AS/NZS 2293, emergency lighting with a viewing distance of 24 metres
- Polycarbonate body profile, IP20, integral 5.6 watt emergency control gear with long life Lithium LifePO4 battery
- Multi-directional decals included
- Versatile design to allow ceiling or wall mount installation, with quick connect removable decal housing
- Guaranteed 90 minutes emergency function
- Optional recessed mounting (SELK1500EX-2RC/P) and end mounting wall brackets (SELK1500EX2WM/P) available



Dimensions

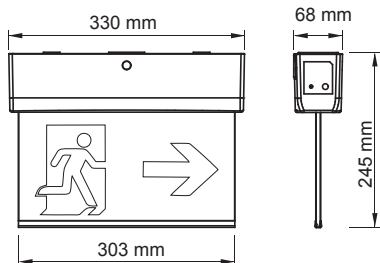

Technical Specifications

Model No.	Input (V)/(Hz)	Emergency Power (W)	CCT (K)	Battery Type	Fitting Colour
SELK1500EX2	240/50	5.6	6000	IFR18650 3.2V, 1.5Ah	White

For terms and conditions of catalogue data use, refer to INDEX



EMERGENCY EXIT SELK1500EX2 ACCESSORIES

SELK1500EX2 Emergency Exit 24 metre viewing



Model No: SELK1500EX2RC/P
Easy slide in recessed assembly

Quick release ceiling mounts

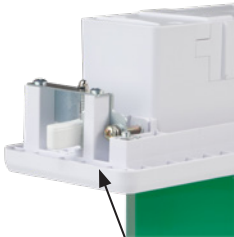

Quick connect
- plug and play assembly



Three sets of directional
decals provided

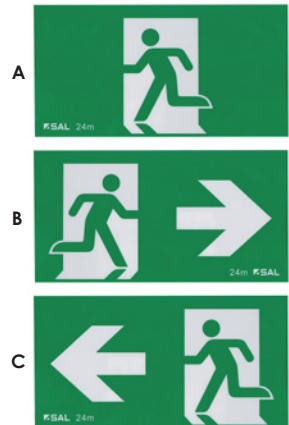



LEDLINE EMERGENCY SLD2000/4000 - 20W/40W

Linear diffuse batten, compliant to AS/NZS 2293 emergency

Application

Wide body profile, perfect for end to end commercial installations



Design Specifications

- Pressed steel body profile
- Powder coat white finish
- Designed with a large terminal block for easy installation
- High efficiency SMD LED chips, CCT 4000K
- Designed to enable end to end installation
- LiFePO4 battery included
- Designed for both maintained and non maintained systems
- LED charge status display and test switch
- Guaranteed 90 minutes emergency function

Dimensions

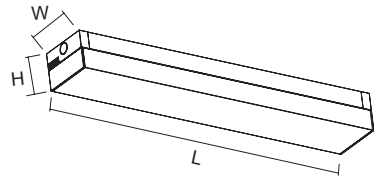

Photometric Data (power on)

Unit: cd C0/C180 — C90/C270

SLD2000CW/EM at 4000K

SLD4000CW/EM at 4000K

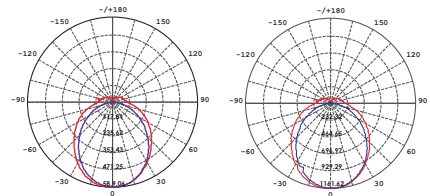

Technical Specifications

Model No.	Input (V)/(Hz)	Emergency Power (W)	Battery Type	Emergency Classification	Dimensions (L x W x H)
SLD2000CW/EM	240/50	1.6	IFR26650 3.2V, 3200mAh	D32@C0, C63@C90	600 x 100 x 77
SLD4000CW/EM	240/50	2.1	IFR26650 3.2V, 3200mAh	D40@C0, C80@C90	1120 x 100 x 77

For terms and conditions of catalogue data use, refer to INDEX



TUBELINE WIREGUARD STG - 18W/36W

Conventional LED bare battens with wire guard protection 18 - 36 watt

Application

Conventional designed bare LED battens with wire guard protection, ideal for commercial interior spaces



Design Specifications

- Pressed steel base with PVC body
- Large terminal block, easy installation
- Powder coated white steel wire guard
- High efficiency LED T8 tubes fitted, CRI > 80, CCT 3000K/4000K/6000K
- Safety fuse installed
- Compliant to AS/NZS2293
- Non maintained, independent emergency end cap with Lithium LiFePO4 battery
- LED charge status display and test switch
- Guaranteed 90 minutes emergency function

Dimensions

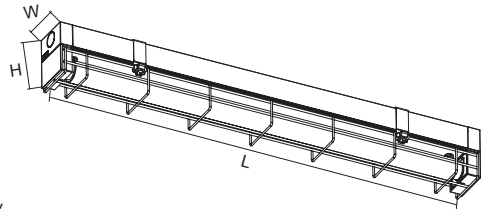

Photometric Data (power on)

Unit: cd C0/C180 — C90/C270

STG/206EM2500 at 4000K

STG/212EM2500 at 4000K

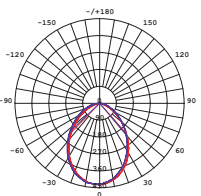
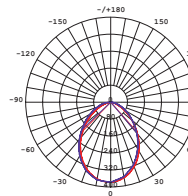

Technical Specifications

Model No.	Input (V)/(Hz)	Emergency Power (W)	Battery Type	Emergency Classification	Dimensions (L x W x H)
STG/206EM2500	240/50	2	IFR18650 6.4V, 1500mAh	D50	655 x 110 x 77
STG/212EM2500	240/50	2	IFR18650 6.4V, 1500mAh	D50	1255 x 110 x 77



STD TUBELINE DIFFUSE - 18W/36W

Conventional LED diffuse
battens 18 - 36 watt

Application

Conventional LED interior battens ideal for residential and commercial service spaces



Design Specifications

- Pressed steel base with PVC body
- Large terminal block, easy installation
- Quality white powder coat finish
- High efficiency LED T8 tubes fitted, beam distribution 120°, CRI >80, 3000K/4000K/6000K
- Safety fuse installed
- Emergency with LiFePO4 battery included compliant to AS/NZS2293
- Non maintained, independent emergency end cap
- LED charge status display and test switch
- Guaranteed 90 minutes emergency function

Dimensions

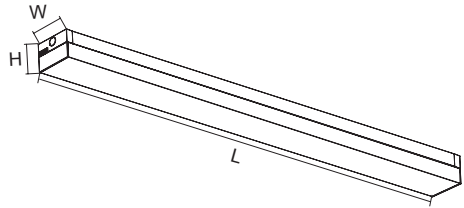

Photometric Data (power on)

Unit: cd C0/C180 — C90/C270

STD/206EM2500 at 4000K

STD/212EM2500 at 4000K

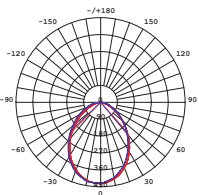
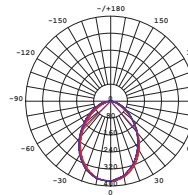

Technical Specifications

Model No.	Input (V)/(Hz)	Emergency Power (W)	Battery Type	Emergency Classification	Dimensions (L x W x H)
STD/206EM2500	240/50	2	IFR18650 6.4V, 1500mAh	D50	655 x 110 x 77
STD/212EM2500	240/50	2	IFR18650 6.4V, 1500mAh	D50	1255 x 110 x 77

For terms and conditions of catalogue data use, refer to INDEX



LED STD25EM - 18W/36W

Wide body LED 18 - 36 watt surface mount diffused linear batten

Application

Conventional linear LED batten profile ideal for residential and commercial spaces

Design Specifications

- Durable metal body profile, white powder coat finish
- High efficiency LED T8 tubes fitted, choice of 3000K/4000K/6000K, CRI>80
- Large terminal block, easy installation
- Safety fuse installed
- High performance PMMA prism diffuser, beam distribution 120°
- Non maintained, independent emergency end cap
- Emergency with LiFePO4 battery included compliant to AS/NZS2293
- LED charge status display and test switch
- Guaranteed 90 minutes emergency function



Dimensions

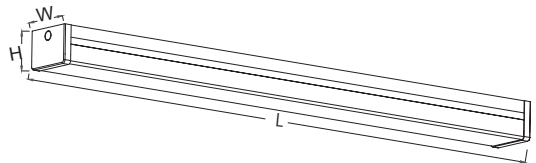

Photometric Data (power on)

Unit: cd C0/C180 — C90/C270

STD25/206EM at 3000K

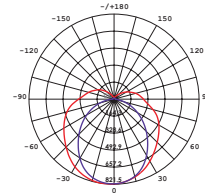

Technical Specifications

Model No.	Input (V)/(Hz)	Emergency Power (W)	Battery Type	Emergency Classification	Dimensions (L x W x H)
STD25/206EM	240/50	2	IFR18650 6.4V, 1500mAh	D50	630 x 109 x 83
STD25/212EM	240/50	2	IFR18650 6.4V, 1500mAh	D50	1260 x 109 x 83



SAL EMERGENCY WE'VE GOT YOU COVERED

The comprehensive range of SAL Emergency LED lighting products cover all your emergency needs; exits, luminaires and more.



LED EMERGENCY KIT SELK1500SM - 2W

SELK1500/SM triangle, non-maintained emergency lighting kit

Application

Perfect for commercial emergency lighting requirements

Design Specifications

- Compliant to AS/NZS 2293, classification D50
- LED charge status indicator and test switch
- Guaranteed 90 minute emergency function
- Intelligent automatic recharging function, with 16 hour charge time
- SELV compliant and can be used with all SAL LED panel luminaires
- LiFePO4 battery included, non-maintained



Dimensions

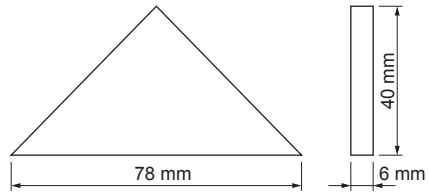

Model No.	Input (V)/(Hz)	Emergency Power (W)	Battery Type	Emergency classification	CRI	Fitting Colour
SELK1500/SM	240/50	2	IFR18650 3.2V, 1500mAh	D50	> 80	Silver



TC SELECTABLE

DUAL POWER

ECOLINE EMERGENCY SL9732EM - 20W/40W

Compliant to AS/NZS 2293,
narrow body profile

Application

Perfect for interior commercial
emergency lighting installations

Design Specifications

- Narrow steel body (65mm) body profile, white powder coat finish
- Designed with a large terminal block for easy installation
- LiFePO4 battery technology for long life
- Designed for both maintained and non maintained systems
- High efficiency SMD LED chips on board
- Selectable colour temperature DIP switch, 3000K/4000K/5700K
- Integral dual power selection
- LED charge status display and test switch
- Guaranteed 90 minutes emergency function



Dimensions

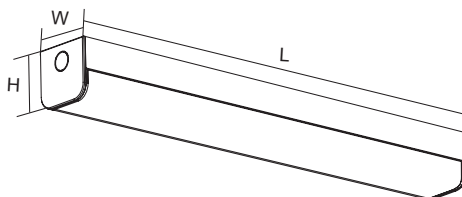

Photometric Data (power on)

Unit: cd C0/C180 — C90/C270

SL9732/20EM at 5700K

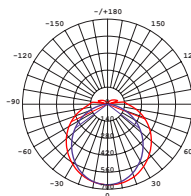

SL9732/40EM at 5700K

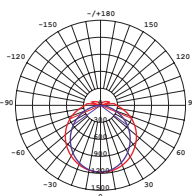

Technical Specifications

Model No.	Input (V)/(Hz)	Emergency Power (W)	Battery Type	Emergency Classification	Dimensions (L x W x H)
SL9732/20EM	240/50	2	IFR26650 3.2V, 3200mAh	D40@C0, D25@C90	600 x 65 x 65
SL9732/40EM	240/50	2	IFR26650 3.2V, 3200mAh	D50@C0, D25@C90	1135 x 65 x 65

For terms and conditions of catalogue data use, refer to INDEX



TC SELECTABLE

OPAL II SO3800EM - 30W

Opal II emergency 30 watt
low profile oyster

Application

Emergency functions, perfect for commercial and apartment requirements

Design Specifications

- Opal polycarbonate diffuser
- Power coated white steel body profile
- Selectable colour temperature with the integral DIP switch, 3000K/4000K/5700K
- Designed for both maintained and non maintained systems
- Compliant to AS/NZS 2293 emergency requirements, LiFePO4 battery included
- LED charge status display and test switch
- Guaranteed 90 minutes emergency function



Dimensions

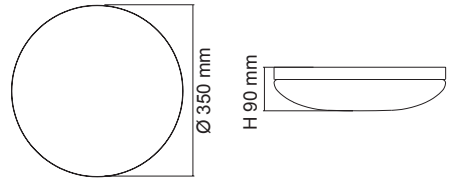

Photometric Data (power on)

Unit: cd C0/C180 — C90/C270

SO3800/40TC/EM at 3000K

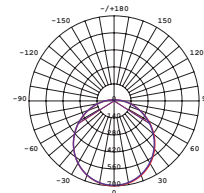

Technical Specifications

Model No.	Input (V)/(Hz)	Emergency Power (W)	Battery Type	Emergency Classification	Dimensions (D x H)
SO3800/40TC/EM	240/50	1.6	IFR26650 3.2V, 3200mAh	D20	350 x 90
SO3800/40TC/EMS	240/50	1.6	IFR26650 3.2V, 3200mAh	D20	350 x 90