

12.1 This tube kit is tested to comply with AS/NZS 60598.2.1:2014

12.2 Notes

- The lamp includes a built-in driver, and is NOT suitable for dimming.
- The lamp is NOT suitable for use in emergency luminaires designed for double-capped fluorescent lamp(s).
- The lamp does NOT exceed the photobiological hazard ratings for Risk Group 1 (low risk), in accordance with Clause 6.1.2 of AS/NZS IEC 624 71 :2011.

12.3 Starter Replacement Fuse

- A fuse provided with the lamp shall be used to protect a fluorescent lamp that is inadvertently installed against short circuits. Each fuse can be used to protect a maximum of two lamps.
- The supplied fuse replacement rating sticker shall be placed on the luminaire and shall be visible during fuse replacement.
- The rating of the lamp shall not exceed the maximum wattage of the lamp that it is intended to replace or the total wattage of the replacement lamps shall not exceed the maximum wattage of the luminaire.

12.4 Important Warning: The luminaire that these LED tubes are installed in may need to be converted in accordance with AS/NZS60598.2.1:2014 by a suitably qualified person. In all instances any electronic components (i.e. driver, electronic ballast, capacitor) must be removed from the circuit.

12.5 Wiring diagram New luminaire example

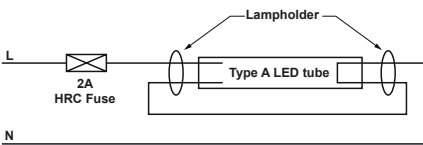

Retrofit or Modified luminaires:
Refer to AS/NZS60598.2.1:2014 for wiring diagrams

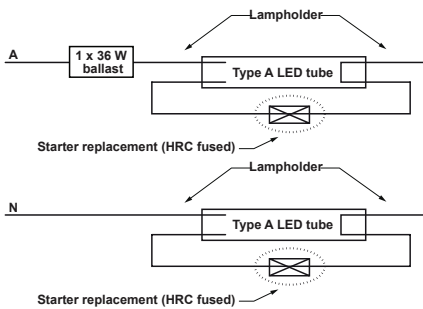
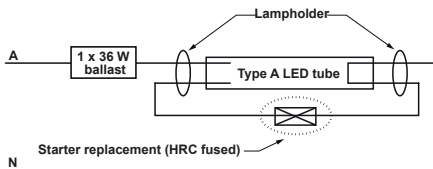

The instructions for lamps intended for use in a new luminaire shall include the following warnings:

WARNING: The supplied warning sticker shall be placed on the luminaire and shall be visible during lamp replacement. **WARNING:** A fuse shall be used to protect a fluorescent lamp that is inadvertently installed against short circuits. Each fuse shall (a) be of the 250 V HRC type; (b) have a 2 A max. quick-acting type rating; and (c) be used to protect a maximum of two lamps. The luminaire shall have a fuse replacement rating label. **WARNING:** The rating of the lamp shall not exceed the maximum wattage of the lamp that it is intended to replace or the total wattage of the replacement lamps shall not exceed the maximum wattage of the luminaire. **NOTE:** Manufacturers should specify minimum requirements for the operations of their lamps, including spacing, enclosure design and temperature limitations.

The instructions for lamps intended for use in an existing luminaire that requires modification other than replacement of the lamp or starter shall include the following warnings: **WARNING:** The manufacturer of the original luminaire will no longer be responsible for the compliance of the modified product. Any modifications made to the original luminaire may alter the safety aspects of the original luminaire; hence compliance assessments of the original luminaire may no longer be applicable to the modified luminaire. **WARNING:** The supplied warning sticker shall be placed on the luminaire and shall be visible during lamp replacement. **WARNING:** A fuse shall be used to protect a fluorescent lamp that is inadvertently installed against short circuits. Each fuse shall (a) be of the 250 V HRC type; (b) have a 2 A max. quick-acting type rating; and (c) be used to protect a maximum of two lamps. **NOTE:** A quick-acting type fuse is defined in the IEC 60127 series as 'Type F'. The luminaire shall have a fuse replacement rating label. **WARNING:** The rating of the lamp shall not exceed the maximum wattage of the lamp that it is intended to replace or the total wattage of the replacement tubes shall not exceed the maximum wattage of the luminaire.

13. **Warranty** – In accordance with SAL's standard terms and conditions of sale, SAL warrant this product to be free from defects in materials and or workmanship for a period as stated below for goods not subject to incorrect installation, maintenance, operation, mishandling, environmental, unauthorised modifications or electrical operating conditions outside the nominated product specification as detailed in these installation instructions. The benefits to you given by this warranty are in addition to other rights and remedies you have under law. Our goods come with guarantees that cannot be excluded under the Australian Consumer Law. You are entitled to a replacement or refund for a major failure and compensation for any other reasonably foreseeable loss or damage. You are also entitled to have the goods repaired or replaced if the goods fail to be of acceptable quality and the failure does not amount to a major failure.

Warranty term – Residential usage (24) months, Commercial usage (12) months, Replaceable Lamps (where supplied) (12) months and Lithium batteries where supplied (24) months from date of purchase. For New Zealand, please refer to www.sal.co.nz for warranty conditions and service.

How to make a claim?

Step # 1 – Within 30 days of the fault discovery, please contact the original place of the SAL product purchase during standard (local) business hours, with the following information (a) proof of purchase (b) description and quantity of the claimed fault (c) address of installation. (d) operating hours of the product.

Step # 2 – It is then the responsibility of the original place of product purchase to report the matter to SAL aftersales;

NSW ACT	- SAL National Pty Ltd, 40 Biloela Street Villawood NSW 2163	P # 02 9723 3099
QLD	- SAL National Pty Ltd, 36 Whitelaw Place Richlands QLD 4077	P # 07 3879 5999
VICT TAS SA NT	- SAL National Pty Ltd, 46-48 Keys Road Moorabbin Victoria 3189	P # 03 9532 3168
WA	- SAL National Pty Ltd, 29 Beringarra Av Malaga WA 6090	P # 08 9248 7458
NZ	- Hamer, 130 Bush Road, Albany, Auckland, 0632	P # 0800 239 239

Step # 3 - Upon review of your claim and if the product is required to be returned to SAL for technical evaluation, then at the owners expense the product must be returned to SAL as per the above nominated locations.

Step # 4 - Pending the evaluation, the claim will be validated resulting in the product being repaired or replaced with the same or best equivalent product at the discretion of SAL, or rejected if the product fault was found to be caused by conditions beyond the responsibility of SAL warranty obligations. Consideration of installation, product removal, return freight and or testing fees are not the responsibility of SAL.

